

January 2013

# Control of Smart Building Using Advanced SCADA

Vivin Thomas Samuel

University of South Florida, [vivinthomas@mail.usf.edu](mailto:vivinthomas@mail.usf.edu)

Follow this and additional works at: <http://scholarcommons.usf.edu/etd>

 Part of the [Electrical and Computer Engineering Commons](#), and the [Oil, Gas, and Energy Commons](#)

---

## Scholar Commons Citation

Samuel, Vivin Thomas, "Control of Smart Building Using Advanced SCADA" (2013). *Graduate Theses and Dissertations*.  
<http://scholarcommons.usf.edu/etd/4935>

This Thesis is brought to you for free and open access by the Graduate School at Scholar Commons. It has been accepted for inclusion in Graduate Theses and Dissertations by an authorized administrator of Scholar Commons. For more information, please contact [scholarcommons@usf.edu](mailto:scholarcommons@usf.edu).

# Control of Smart Building Using Advanced SCADA

by

Vivin Thomas Samuel

A thesis submitted in partial fulfillment  
of the requirements for the degree of  
Master of Science in Electrical Engineering  
Department of Electrical Engineering  
College of Engineering  
University of South Florida

Major Professor: Zhixin Miao, Ph.D.  
Lingling Fan, Ph.D.  
Wilfrido Moreno, Ph.D.

Date of Approval:  
November 5, 2013

Keywords: Alarms, FDD, Estimation, Savings, Chillers

Copyright © 2013, Vivin Thomas Samuel

## **DEDICATION**

To my Parents

D.W.Samuel & Nirmala Samuel

## ACKNOWLEDGMENTS

I am honored and privileged to thank my advisor Dr. Zhixin Miao, Ph.D., for his guidance, encouragement, and continuous support throughout my MSEE program. I wish to thank my Co-Professors, Dr. Lingling Fan, Ph.D., Dr. Wilfrido Moreno, Ph.D., for their continuous support and guidance.

I shared so many things with them over the years that we spent together. They also taught me so many virtues, friendship, unselfishness, tolerance and helpfulness. I am grateful to them for making me a better person.

My Sincere appreciation goes to my parents who stood beside me and encourages me throughout my life. I thank them to have trust in me and allow me to pursue my higher studies.

## TABLE OF CONTENTS

LIST OF TABLES .....	iii
LIST OF FIGURES.....	iv
ABSTRACT.....	vi
CHAPTER 1: INTRODUCTION .....	1
1.1 Importance of BMS .....	2
1.2 Fault Detection and Diagnosis .....	4
1.3 Maestro Software .....	8
CHAPTER 2: DEMAND SIDE MANAGEMENT & DEMAND RESPONSE IN SMART BUILDING.....	10
2.1 Demand Power Management .....	10
2.2 Time Management.....	11
2.3 Increasing Demand Side Management.....	11
2.4 Energy Efficiency.....	11
2.5 Controller Operation .....	12
2.6 Demand Response .....	15
2.6.1 Duration of the Activity .....	15
2.6.2 Plant and Equipment .....	15
2.6.3 Temporary Lighting & Power .....	15
2.6.4 Personnel / Training .....	15
CHAPTER 3: OVERVIEW OF THE SYSTEM.....	16
3.1 Block Diagram of the System .....	16
3.2 Mechanism of the System .....	17
3.3 Logic of the Mechanism.....	18
CHAPTER 4: DATA COMMUNICATION OF ADVANCED SCADA .....	19
4.1 Implementation of Operational Intelligence .....	19
4.1.1 Centralized Data Improvement .....	19
4.1.2 Advanced Load Analytics .....	19

4.1.3 Environmental Management .....	20
4.1.4 Advanced Alarming and FDD.....	20
4.1.5 Efficient Usage of Chiller Plant .....	20
4.2 Detection of Human Activity and Control of the Chiller.....	24
4.2.1 IETC 603470-5 Protocol .....	25
4.2.2 T101 Protocol.....	26
4.2.3 Conitel .....	27
CHAPTER 5: CONTROL OF THE SYSTEM USING SCADA .....	28
5.1 Ethernet Logic Controller.....	29
5.2 Implementing SCADA to a Building BMS .....	32
5.2.1 General Information of the Site .....	32
5.2.2 Systems Description.....	33
5.2.3 Facility Energy Consumption Statistics Table .....	35
5.2.4 Floor Plan .....	36
5.3 Coding Flowchart.....	36
CHAPTER 6: CONCLUSION.....	37
REFERENCES.....	38
APPENDICES.....	40
Appendix A General Information About Appendices.....	41

## LIST OF TABLES

Table 1: Ways to Save the Energy Consumption.....	08
Table 2: Facility Energy Consumption Statistics.....	35
Table 3: Energy Consumption Table .....	35

## LIST OF FIGURES

Figure 1: The Effects of Electricity as Building Energy Resources .....	6
Figure 2: Sales Between Industry and Building.....	7
Figure 3: Energy Information System (EIS) .....	12
Figure 4: Analyzing Demand Power.....	14
Figure 5: Block Diagram of the Building Management System.....	16
Figure 6: Architecture of Proposed System .....	17
Figure 7: Chiller Plant HMI Interface .....	22
Figure 8: A Chiller System .....	23
Figure 9: Cooling Tower Optimization HMI Interface.....	23
Figure 10: SCADA Protocol Distribution.....	24
Figure 11: IETC 603470-5 Structure .....	25
Figure 12: Overview of T101 Protocol .....	26
Figure 13: Network Topologies of T101.....	27
Figure 14: Ethernet Logic Controller.....	29
Figure 15: System Architecture for Energy Consumption.....	36
Figure 16: Coding Flow Chart for a Proposed System .....	36
Figure A.1: Control Diagram of SCADA PLC.....	42



Figure A.2: A Runtime SCADA Controller.....	43
Figure A.3: B&R OPC Monitor Tool .....	43
Figure A.4: Using VNC for Remote Access and Control.....	44
Figure A.5: VNC SCADA Panel.....	44
Figure A.6: SCADA Server Simulator.....	45
Figure A.7: SCADA Simulator Manager.....	45
Figure A.8: SCADA Server Simulation.....	46

## ABSTRACT

For complete control of the building, a proper SCADA implementation and the optimization strategy has to be build. For better communication and efficiency a proper channel between the Communication protocol and SCADA has to be designed.

This paper concentrate mainly between the communication protocol, and the SCADA implementation, for a better optimization and energy savings is derived to large scale industrial buildings. The communication channel used in order to completely control the building remotely from a distant place. For an efficient result we consider the temperature values and the power ratings of the equipment so that while controlling the equipment, we are setting a threshold values for FDD technique implementation. Building management system became a vital source for any building to maintain it and for safety purpose. Smart buildings, refers to various distinct features, where the complete automation system, office building controls, data center controls. ELC's are used to communicate the load values of the building to the remote server from a far location with the help of an Ethernet communication channel. Based on the demand fluctuation and the peak voltage, the loads operate differently increasing the consumption rate thus results in the increase in the annual consumption bill. In modern days, saving energy and reducing the consumption bill is most essential for any building for a better and long operation. The equipment - monitored regularly and optimization strategy is implemented for cost reduction automation system. Thus results in the reduction of annual cost reduction and load lifetime increase.

## CHAPTER 1: INTRODUCTION

Smart Building has the “property” to dynamically managing its personal energy demand and the energy generation. In other words, we can say it will consume, shift and originate energy when appropriate — allowing you to minimize your total energy spending and carbon footprint without compromising comfort, convenience and safety. Smart Building is an office building or commercial complex with increased environmental and economic work performance. The building accomplishes this by storing, efficiently managing, producing, and optimally controlling energy.

Energy wastage can be removed by obtaining location information for individuals while ensuring building safety, security, automatically controlling air conditioning and lighting, and visually showing energy use. Energy measurement may also be helpful to ensure the security of the whole building. Buildings that make building management more efficient and curb energy consumption, from the building over all down to an individual level - those are a Smart Buildings.

A smart building’s help to moderation of need facilities with the best goals. By building a bi-directional energy flows between an on-site generation and storage systems and the outside electrical grid, a smart building can handle energy supply and demand to help remove energy waste and reduce the greenhouse gas emissions. Energy management will take place much more denaturalized through the enhanced use of resources, distributed renewable energy generation assets like wind, bio-gas and solar photovoltaic, and the potential for real-time pricing.

To compete effectively, facility owners and managers will be challenged with efficiently balancing their energy supply and demand resources without negatively impacting the comfort, convenience, safety and productivity of the people in their building [1].

Building Management System (BMS) is a part of smart building. This is installed in a building to maintain and control the electrical equipment, Chillers, fire alarms and security systems. BMS is comprised of following tools. Energy meters, controller unit, gateway server and control software [2][3].

### 1.1 Importance of BMS

Buildings in modern days have fully loaded with electrical and mechanical principles which are helpful for the maintaining and for basic facilities to the building. In general buildings should have provision for the people to use efficiently and easily. For examples a building should be equipped with air-condition and boiler. Boilers are used to distribute hot water throughout the building and in order to maintain it there should be an easy passage way for water flow and necessary cooling equipment for the emergency case. In order to satisfy this need, a building should have a Building Management system where it takes control of the entire electrical and mechanical structure of the building. The safety lies in the management system installed in the building. It controls manually or automatically and sends a signal when there is any emergency situation like fire alarms. It is the main brain of the building which controls the elevator, lights, air-condition, heater and boiler.

The control of the building is the important part of any building architectural plan. In order to get a best control strategy, we need to focus on the building mechanical and electrical structure. This can be done by having an initial site visiting and to take a complete understanding

of the construction. During the site visit we have to follow some of the important information as follows.

- (a) Floor plan: It is necessary to get the floor plan of the building or else by looking at the building draw manually a rough floor plan. On the floor plan, note down the important load, supply vent and the return air duct.
- (b) Load location: To figure out the loads on which distribution board it is connected, location of the load and the distance between the load and the distribution board. This helps for an installation of the controls in the building.
- (c) Basic information of the building: Information like a total number of people working on the building, hours of operation, the number of loads installed on the building, installation of fire alarm of the building and the building management system installed on the building.
- (d) Chiller information: Figure out the chiller location, Manufacturing details, power ratings, hours of an operation of the chiller, the number of people get the use of the chiller, thermostat location, backup chiller, return air vent and the supply air vent.
- (e) Temperature Sensor installation: Understand the work area to install the temperature sensor to get the accurate value of the temperature with respect to the chiller output. This is helpful as to control the chiller based on the demand of temperature. Mark the spot to install the temperature sensor on the floor plan provided.
- (f) Controls installation recommendation: To implement the control for the building, we have to find out the place to install the SAM meter and the ELC's on the building. It should not be very far from the distribution board as the installation cost more if we install the control equipment far from the load.

- (g) Strategy for load optimization: Based on the information collected, it is necessary to set the control strategy to get the better optimization plan. This can be done with the help of load installation, power rating of the load, room temperature and the location of the load.
- (h) Report generation for installation of controls: Each load should be connected with a CT's to get the electrical readings. CT's are connected to the SAM meter, where the current readings are converted into power and voltage readings. These values are collected with the help of ELC, where it reads the data from SAM and send it to the gateway computer installed in the building with the help of the Ethernet cable. Then the gateway computer is taken into remote access from a distance location with the help of the IP address of the gateway computer. By this we have the data from a distance location and this data and fed into the SCADA software for the control strategy.
- (i) SCADA implementation: The data we collect from the gateway computer is analyzed and keeping the set point for each of the loads, temperature sensors, fire alarms and the other production load installed on the building. Keeping this set point controls the loads from a distance place, where it sends the signal back to the ELC through the gateway computer. ELC is connected directly to the load with a point list. By changing the input, the load is controlled from a far location. This is a closed loop where the readings are collected, analyzed and transmitted back to the load.

## 1.2 Fault Detection and Diagnosis

The process where the data is sampled, analyzed eliminating the feedback and setting up the threshold values for the proper control of the system is said to be FDD. The equipment's are installed and monitored; the values are then analyzed with a strategy to find the threshold. This threshold is then fed into the control SCADA to get the better efficiency of the system. The FDD

threshold to be set according to the system and their operation, thus gives a complete control of building management. FDD are frequently used for the operation of chiller and AHU controls, where the percentage of equipment and operation failure is more. FDD are set based on the following information:

- (a) The maximum operation of the equipment.
- (b) Demand power fluctuation of the load with respect to time.
- (c) A peak voltage of the load during daytime.
- (d) The time of operation.

Based on the above information, the set point is set on the system. If there is any change in the set point observed on the load, the alarm is triggered mentioning the output of the equipment and the recommendation to be followed to bring back the system into normal operation. Sometime it is observed that the load is pulling more power than the optimum level. This results in abnormal demand fluctuation, excess consumption of energy and increase in the monthly tariff. To avoid that the set point has to be set wisely and controls are given to the electrical system of the building.

The load should be isolated, if it overcomes the threshold level. It is not necessary to find out the actual problem of the equipment or the energy consumption of the load; however it should be able to isolate the load during faulty condition.

The annual consumption of energy used by U.S. buildings is about \$459 billion in 2012. Among this more than 50 percent of the energy is used for Office and data center. Data center need more energy to maintain the entire building at low temperature.

The reason for this consumption charge is as follows:

- (a) Increase in the population, which resulted in the construction of new building, schools, commercial building.
- (b) Economic growth of the companies, which leads to increase their man power and office space. Due to this many chiller loads and equipment are installed in the building.
- (c) The increase in the size of the commercial building and houses.
- (d) Increase in equipment like air conditioning, fans, lighting and elevators.
- (e) The actual price of energy consumption was increased by the government.

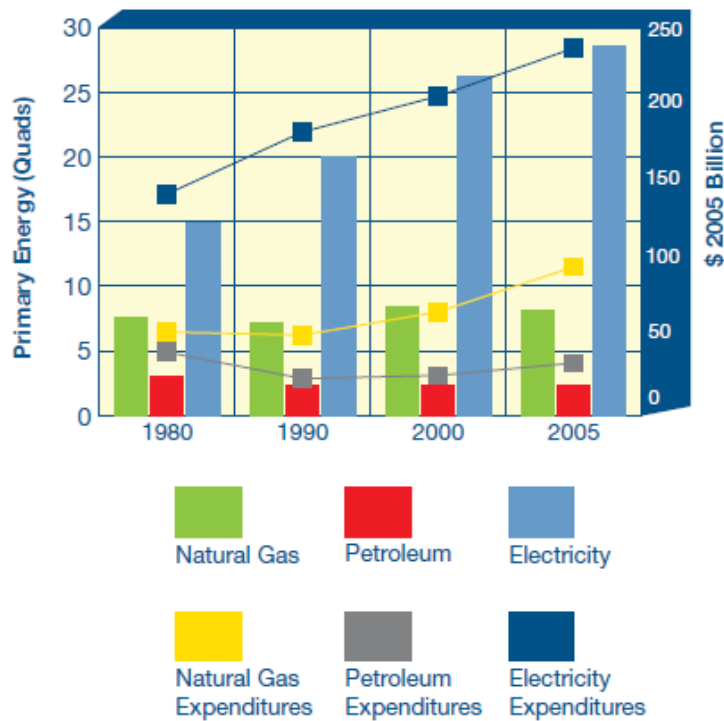

Figure 1: The Effects of Electricity as Building Energy Resources



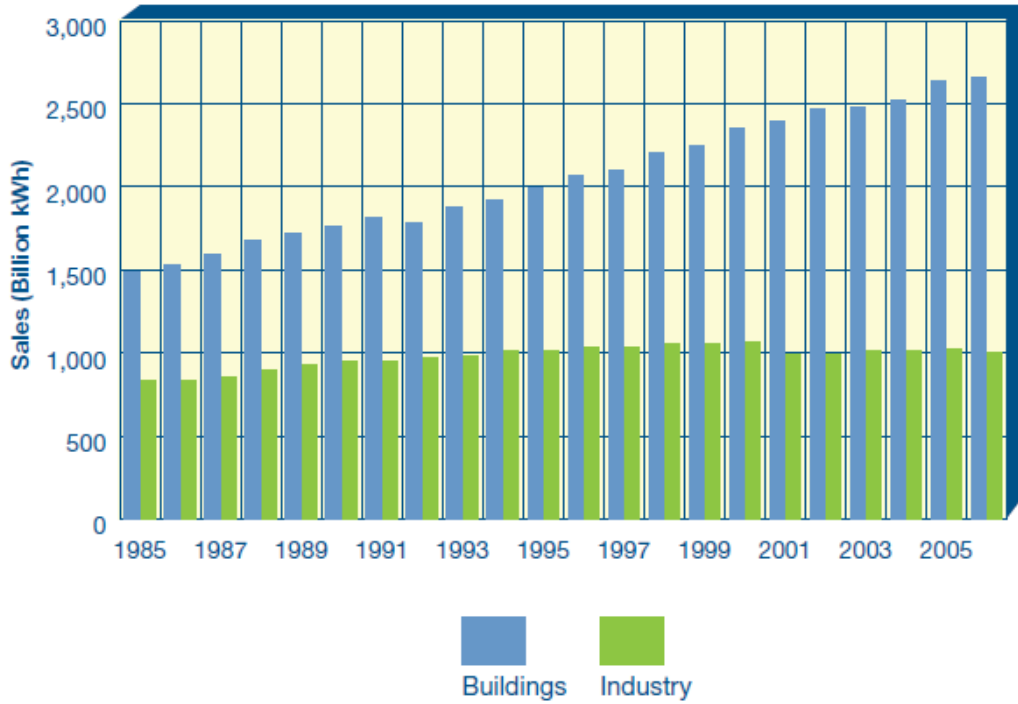

Figure 2: Sales Between Industry and Building

During the year 2000 to 2010, consumption tariff of commercial buildings, residential and retail shops are increased by 2,240 billion kWh, increase of over 88 percent. During the same course of time, demand power and peak voltage charge was increased by 195 billion kWh, which is more than 30 percent. Based on the information, the consumption charge of the retail and commercial buildings are increased and it is reported by the EIA from year 2000 to 2010, more than 85 percent is due to the commercial and residential complexes. This huge increase in demand and consumption ration, the need for the natural resources is increased and the price to buy coal, natural gas and all petroleum product rates are increased dramatically [6].

In general, there are many ways to save energy. It is our responsibility to use the energy wisely and efficiently.

Table 1: Ways to Save the Energy Consumption

Control	Usage cost(\$)	Annual savings(\$)
Usage of heaters only on the place where people live	\$80	\$1023
Usage of ceiling fan instead of Air conditioner.	\$150	\$438
Light is switched off, when not in use.	\$0	\$274
Usage of laundry rack instead of dryer.	\$20	\$196
Keeping the computer in sleep, when not in use.	\$0	\$178
Using washer with cold water, instead of hot water.	None	\$155
Avoiding 100 watts bulb.	\$0	\$141
Converting the 60-watts bulb with fluorescence.	\$35	\$143
Total	\$230 (once)	\$2520 (every year)

### 1.3 Maestro Software

Maestro Software is a publicly available version of the software which is used by the NASA Mars Exploration Rover team to see images collected from rovers and plan the team's daily activities. This is a scaled-down version of the program used to monitor and operate the Spirit and Opportunity rovers. Maestro code written in Java, so it will run on many different

platforms including , Macintosh, Solaris, Microsoft Windows, Linux, ad Irix. The software, along with companion datasets, may be got from Maestro Headquarters. This is a Microchip Application and it is an individual tool to analyze and control the system. It has as in-built graphic modules, where the implement of the high level energy savings and control is possible. Coding is given using MATLAB, where the tool is a user friendly so that we can set the demand and the requirement varied for each equipment and room. The line of control is that, the laod is connected with CT's and the values are recorded by the SAM meter and send to the gateway server computer using ELC. Then the gateway server is logged in remotely and the values are observed from a distant place where the Maestro software is installed and based on the outcome, controls are sent back to the gateway computer and to the loads through ELC's [9][10].

Maestro is used for the implementation of smart building in the industrial or commercial building, where a large energy is wasted for the demand side load. The fluctuation of the load is monitored and entered into the Maestro. It is then processed and analyzed to get various outputs, so that the optimum level and set point is found. This set point and optimum level is used on the site using Maestro to maintain the building in a controlled manner, so that the energy management is maintained and we can get a lot of savings.

The advantage of Maestro is that, it is an open tool where we can dump the data, easily analyze the results and user friendly to feed the data back and to control the system from a very far end to control the entire building remotely without any cost increase. Using Maestro, we can achieve the energy saving cost to a maximum level.

## **CHAPTER 2: DEMAND SIDE MANAGEMENT & DEMAND RESPONSE IN SMART BUILDING**

Demand-side management is used to abate electricity use through software or programs that stimulate electric energy efficiency or maintenance, or more potential management of electric energy loads. The main effort of activities giving limited availability control of customer apparatus such as air conditioners.

### **2.1 Demand Power Management**

In US majority of the commercial building is charged based on the demand electric peak. This electric demand is based on the hours of operation of the equipment where it is generally from afternoon to evening. Depending upon the hours of demand peak electricity, it is necessary to use the device. Suppose the peak electric consumption is from 3PM to 9PM, we can use the corresponding load previously and maintain the temperature with the help of fan running on the room. The majority of the buildings have the peak electric consumption where the peak time is divided into various divisions as Off-Peak, On-Peak and Full load peak. This can be reduced by understanding the building power usage, time of an operation of the equipment, outside air temperature to maintain the room temperature in a constant level and by using an open air method. Hence using the demand electric consumption according to the plan will save a lot of money.

## 2.2 Time Management

Depending upon the time, many building will have demand time charge. During daytime the consumption charge is more than the other time of the day. Based on hours of operation, it is necessary to use the equipment wisely.

## 2.3 Increasing Demand Side Management

In future, it is evident that the power generation unit is closely combined with demand side energy. So it is essential to closely relate the energy management with the energy generation.

## 2.4 Energy Efficiency

In order to improve the energy efficiency of the building; the complete site has to be observed clearly. There is a chance that already some of the equipment like boiler, fans and chiller may malfunction also the energy may be wasted by dirty filter; broken equipment; compressed air leakages. Also check whether the devices are serviced periodically.

- (a) Site information, floor plan, electrical circuit installation plan is to be identified and keep a note of it.
- (b) Try to find the interface that helps in communicating with the electrical circuit of the system.

The Electrical evaluations are as follows.

- (a) Comparison of a load with the peak demand: If there is a high peak voltage identified in the system, then it shows that the device is old or not serviced.
- (b) Periodic checking of the electrical imbalance in the system: Lightning and other loads are monitored that it may be used during the night.

- (c) Identification: Analyzing the complete site, with their peak demand voltage and the hours of operation of the site.
- (d) The correlation of Process: If the energy consumption strongly related with the outside air temperature and the gain. Then it is needed that the system have lots of peak demand voltage, where it should be taken into SCADA algorithm and reduce the over consumption of the device with frequent monitoring.

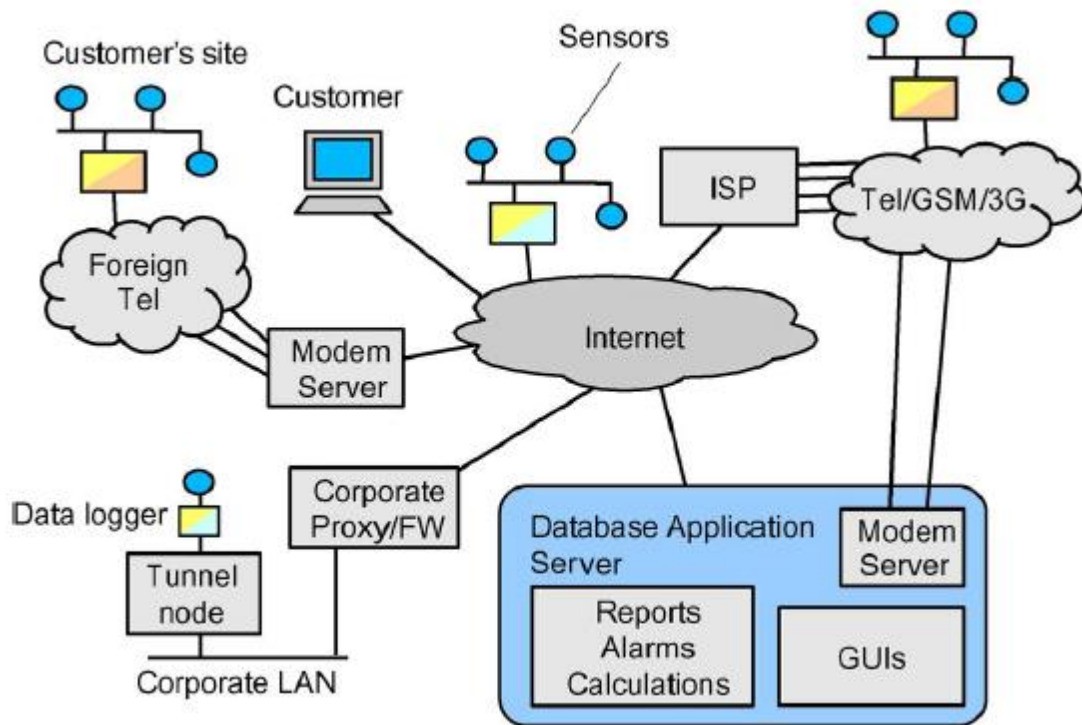

Figure 3: Energy Information System (EIS)

## 2.5 Controller Operation

Energy controllers can be used if the system requires a consumption driven practical output to show a changes with the corresponding increment in the efficiency. The control starts from the load where the energy meter or CT's are used to get measurement.

The measurements are sent to the main control equipment with the process of biasing to convert into binary codes. In figure 5, we are trying to prove the fluctuation of demand power with respect to a time matter a lot for energy saving. During the different interval of time, there is frequent and abnormal change in demand power; this is because of the uneven operation of the equipment. This causes the decrease in the lifetime of the equipment and also increases the monthly consumption bill.

The graph shows the demand power variation with respect to time. By sampling this demand power with the time and finding out the time at which the demand power fluctuation is more and sending recommendation to the concern building to operate at the optimum level to decrease the demand power fluctuation. It is possible to decrease this huge fluctuation using SCADA as taking the equipment into remote access and setting the set point at which the equipment should run on optimum level and the equipment should shut down or send the alarm signal to the concern electrical person on the site to frequently service the equipment.

Once the alarm is triggered, the onsite engineer has to check the equipment, whether it runs more than its time limit or working without any load. If there is any issue with the equipment then the site engineer has to repair the unit or has to totally change the equipment. Based on the fluctuation of demand power the equipment can be controlled by scheduling, this will maintain the frequent fluctuation of the equipment and maintain the demand power at an optimum level. This helps in maintaining the equipment and also increases the lifetime of the system.

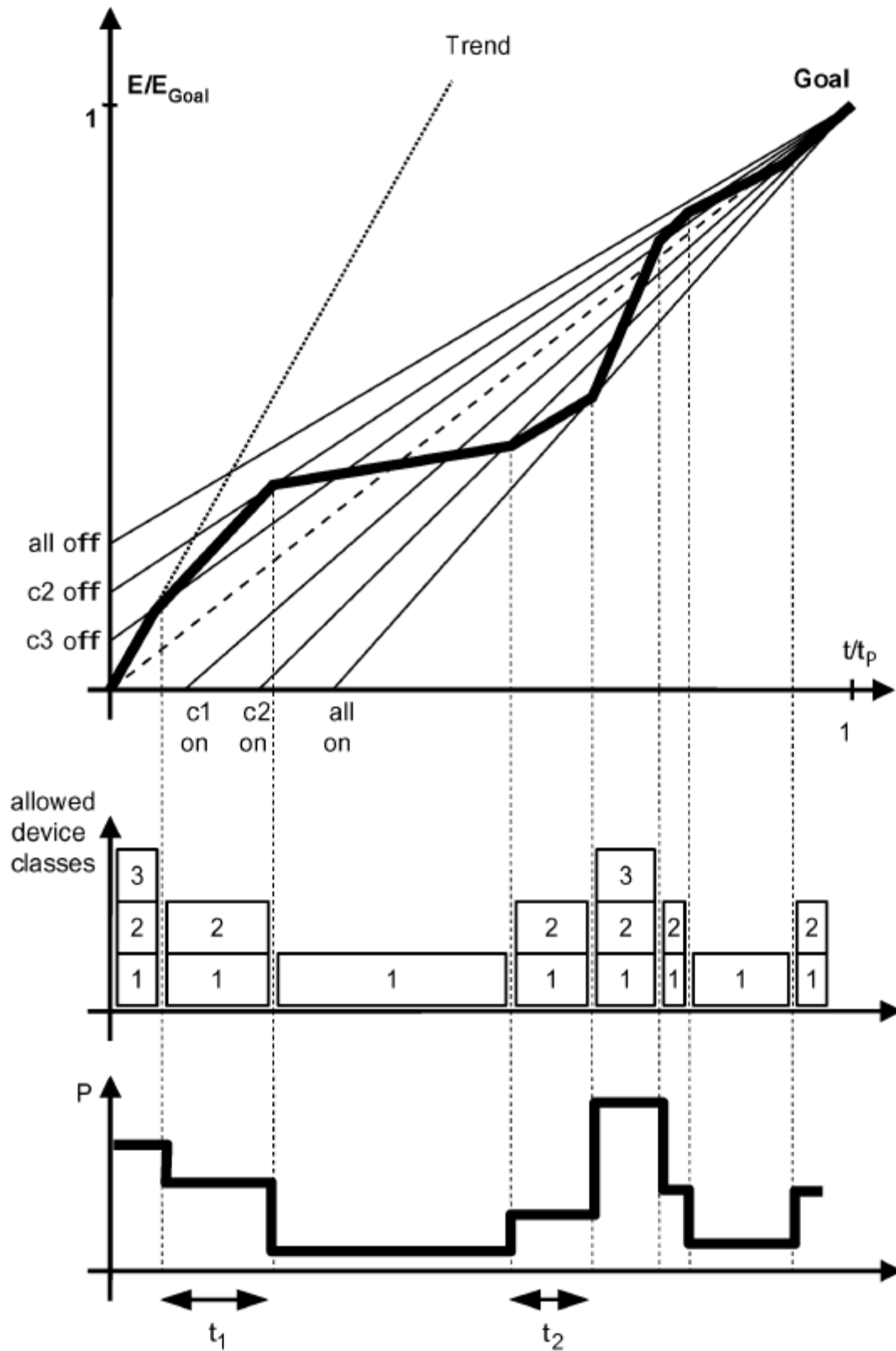

Figure 4: Analyzing Demand Power



## 2.6 Demand Response

### 2.6.1 Duration of the Activity

Within each location, the work is limited to an installation of Daisy Chain AHU wiring, and it is envisaged that the works carried out should last no more than 1 day per area in total. The works associated with the same shall be limited to install of cable to the location of the AHU's only and shall not involve intrusive works within the AHU's.

### 2.6.2 Plant and Equipment

Insulated Wooden Step Ladders and other handheld tools such as screwdrivers, wrenches, pliers/grips, spanners, etc. must be insulated and under no circumstances shall other tools be used especially when working on or near data cabinets or distribution equipment.

### 2.6.3 Temporary Lighting & Power

It is not envisaged any temporary lighting shall be necessary for the task as adequate lighting has been observed on initial visit. Therefore, it is necessary to conduct many site visits to get the better understanding of the loads.

### 2.6.4 Personnel / Training

Personnel will be trained as required, but in general it comply with all scope of works and training, when scaffolds are required be PASMA trained, as a minimum requirement all operatives will possess CSCS accreditation and undertake any specific training necessary or determined by the task to be performed and executed correctly. CLASS A Competency 4 Certified Engineer to be on-site at all times [11].

## CHAPTER 3: OVERVIEW OF THE SYSTEM

Controlling and maintaining various building devices is a major issue in these days. Such devices installed in buildings and take extra power than needed. Thus we focused on these issues and given a new advanced SCADA controller to control all the devices in such a manner that all the devices consumed efficient power as needed. Below we are presenting our proposed system diagram and architecture.

### 3.1 Block Diagram of the System

In this chapter we are giving a detailed block diagram for the current system.

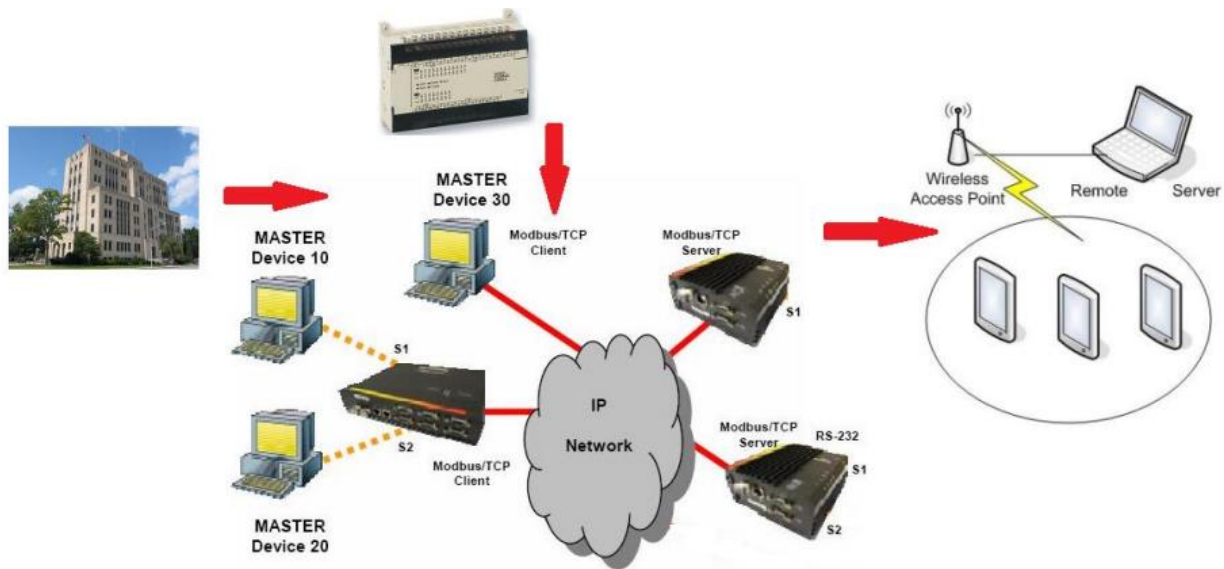

Figure 5: Block Diagram of the Building Management System

In building management system, we can connect various devices through wired and wireless connection. The above figure shows the various devices connected through an IP network via wire connection. Various master devices are connecting through gateway server. In any building, there may be various devices which need to control by remote server. It can be efficiently achieved by using wireless connection. Thus various master devices can be connecting via IP network and can easily control by remote server.

### 3.2 Mechanism of the System

In this section, we are describing the mechanism of our given system. It shows all the steps starting from beginning from end. The block diagram of the system is given below.

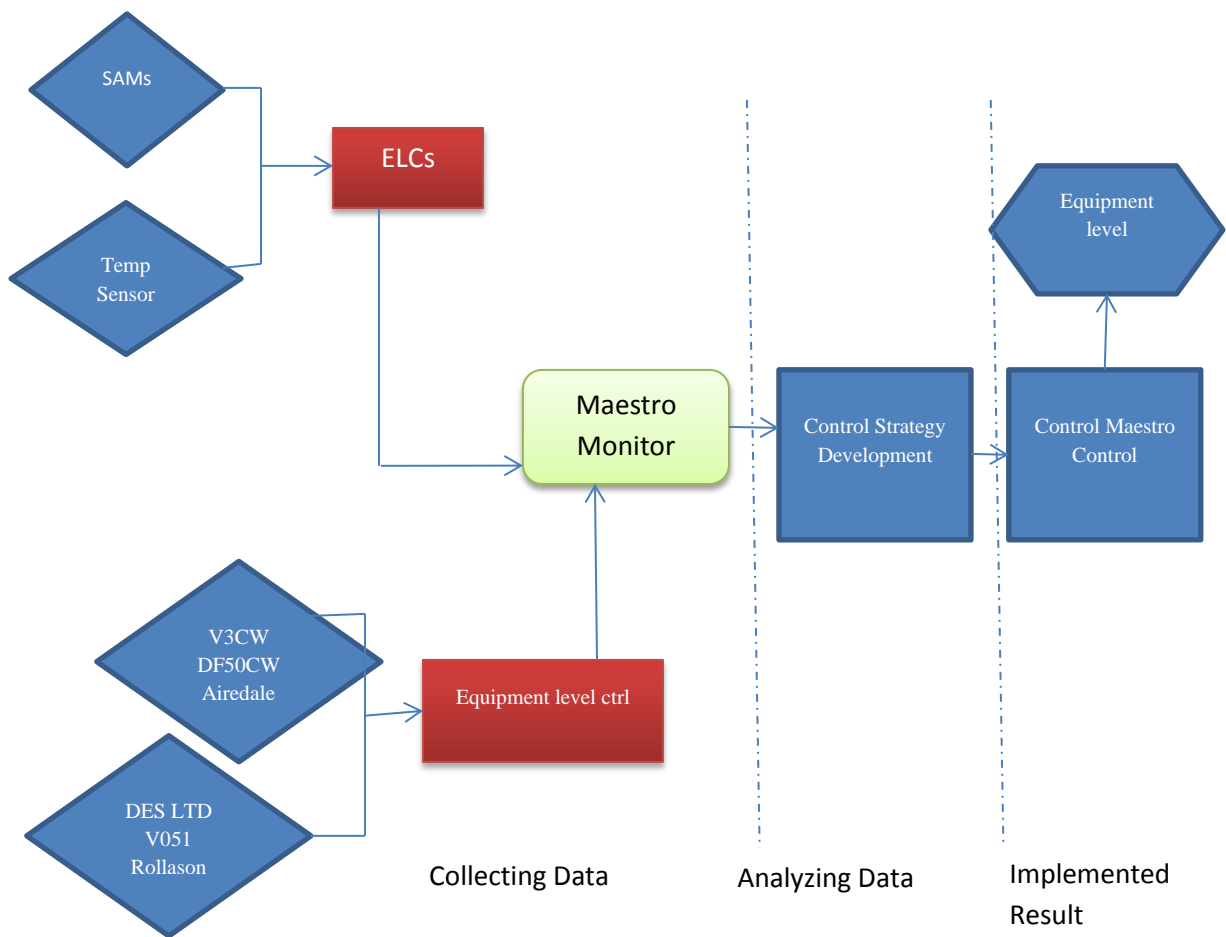

Figure 6: Architecture of Proposed System

In any building, there might be many devices. The main aim of our proposed methodology is to use power in efficient manner. Controlling all the devices at the system level is not useful for efficient power consumption.

### 3.3 Logic of the Mechanism

We are here to show how to control an entire building is controlled remotely from a distant location to monitor the load fluctuation and to control it using a SCADA technology. This in fact saves the energy consumed and reduces the cost of the building.

The loads are classified as electrical, mechanical and production load. Based on the initial analysis of the building we figure out the type of load which the building is consuming and based on our initial report, we are making a plan to take control that particular load. SAM Meters are connected to each load and Current Transformers are connected to each 3 phase load to get the electrical values of that load, which is recorded by the SAM Meter and send it to the ELC. ELC has a self I/O boards which gets and send the value. The value recorded on the SAM Meter is received by the ELC and with the help of Ethernet port sends the details to the gateway server located in the same building. Each gateway is assigned by name on the IP configuration and also the SCADA is installed on the gateway computer and also on the main computer located at a very far distance. With the help of the WLAN, the gateway computer is accessed by the IP address and the remote session is taking place, where the load information is transferred to the main computer. Since SCADA is installed on the Main computer, we can take remote access and monitor the load and also send back the signal to the chiller. That's how the load is monitored and controlled from a distant place efficiently.

## CHAPTER 4: DATA COMMUNICATION OF ADVANCED SCADA

### 4.1 Implementation of Operational Intelligence

#### 4.1.1 Centralized Data Improvement

SCADA provides a central repository for data collection and presentation. Meter and sensor data is collected and transmitted to the SCADA server at periodic intervals. Field values (attributes such as address information, and baseline values) can be manually entered. A gateway server running Control SCADA can interface with a BMS (with support for over 172 communications drivers), to query and optionally write to tag values, and feed these to SCADA. Virtual Data Sources are used to script the calculation of aggregate data, and other complex or composite values; these can be scheduled to execute periodically, or triggered to execute when values change.

#### 4.1.2 Advanced Load Analytics

It is essential to accurately quantify all the four major loads (Total Building Load, Mechanical Load, Plug and Lighting Load and Production Load). Implementing dedicated meters will help monitor and establish base line requirements for facility operation. Adjust temperature set points, lighting and plug loads in non-critical areas during peak consumption. By sub-metering each operational area and any number of specific components within a facility, Maestro™ can provide a detailed analysis of energy consumption and opportunities for optimization focused on HVAC operations, environmental conditions, scheduling and set-point changes.

#### 4.1.3 Environmental Management

Temperature sensors installed in various points throughout a facility are monitored in Real-Time, zone variance, and values outside of defined limits trigger alarm notifications inciting automated control actions or facility operators to take action. The environmental management function automates enforcement of space temp standards across all facilities. Experience suggests this feature can contribute 40% of overall energy savings.

Example: Real-Time Zone Monitoring Trends.

#### 4.1.4 Advanced Alarming and FDD

By leveraging Maestro's access to both meter and BMS data, it combines multiple layer alarming variables to provide powerful fault detection. These alarms include a list of recommendations and estimate consumption and/or cost of alarm activations. Maestro™ also allows users to see a graphical snapshot of the property values that led to the triggering of the alarm at the time when it triggered. Finally, these alarms feed into an Energy Optimization Plan, where remediation workflow and savings are tracked.

#### 4.1.5 Efficient Usage of Chiller Plant

- (a) Planning Chiller operation time – Based on the demand of the chiller during the interval of time, it has to be turned on. The HVAC of the system really depends on the demand of the scheduling. The chiller attains its maximum efficiency only on its full power of operation with respect to time.
- (b) Increasing the coolant of the chiller – Maximum usage of the system and the efficiency of the chiller will come hand in hand only if the chiller thermodynamics is varied frequently. So that the difference of the temperature of the chiller water varies in order to

a evaporator temperature and therefore it reduces the actual consumption of energy to the entire system.

- (c) Decreasing the temperature of the condenser – Similar to that of the increasing the coolant of the chiller, we have to decrease the temperature of the lift that usually flow from the chiller to keep the surface temperature low.
- (d) The water level of the condenser is maintained – If there is any block in the pipe which connects from the chiller to the condenser should be monitored regularly. If suppose any change in the flow of the chiller from the condenser then it has to repaired and frequent checking in necessary.
- (e) Decrease the excess consumption of power to the chiller – The energy used for the tower fan and the condenser is relatively high when compared to the normal flow of the coolant in between the chiller and the condenser. To maintain the regular consumption of the power, we have to keep the fan running when the chiller need is not required.
- (f) Letting the outside air inside – Generally the outside air temperature will be low during the night time when compared to the morning. So we can let the outside air temperature to flow in the chiller to maintain the steady temperature inside the building. This will drastically reduce the power consumption to the chiller.
- (g) Free Cooling – Taking the outside air temperature into account and analyzing the data available for necessary report. The outside air can be used inside the building with the help of the economizer. This will allow the outside air to flow through the building and used to maintain the optimum temperature without operating the condenser unit.

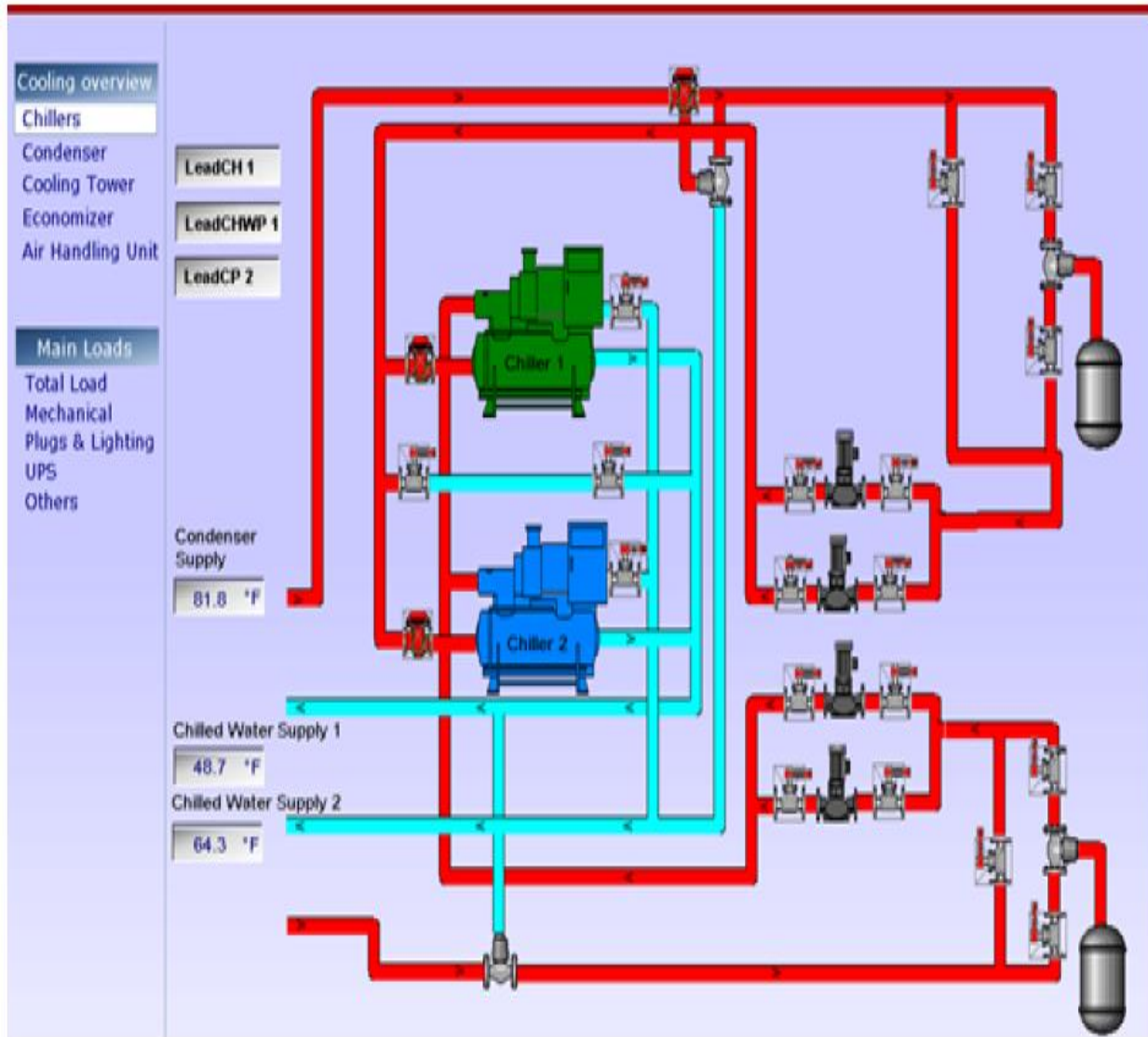

Figure 7: Chiller Plant HMI Interface

The chilled water is allowed to pass through the condenser to the coil through a pipe. It is kept at constant temperature to get the better efficiency of the unit. The various chiller supplies are controlled from a compound point to maintain the chiller temperature is optimum level. Maintaining the chiller level at optimum level will increase in productivity and decrease the cost of the entire chiller system.



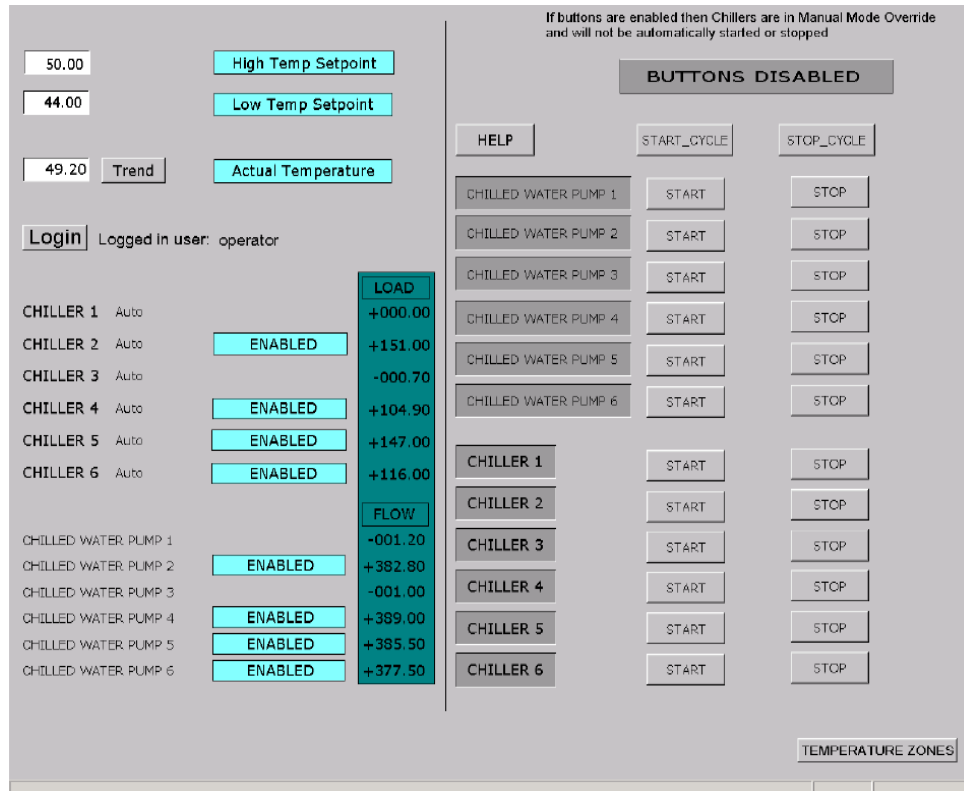

Figure 8: A Chiller System

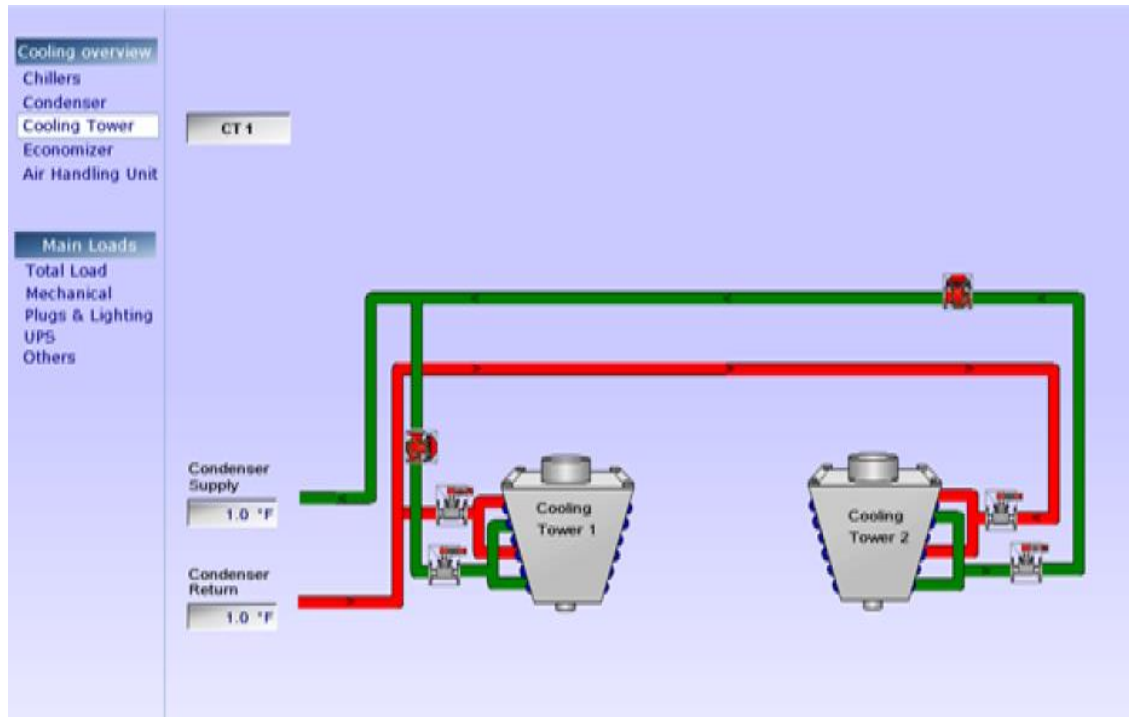

Figure 9: Cooling Tower Optimization HMI Interface

## 4.2 Detection of Human Activity and Control of the Chiller

In many building the temperature is maintained based on the number of people working on the floor. Here the human sensor detector is used to monitor the presence of people in the building and based on that the chiller scheduling will be done.

This technology is used based on the GPS and the control slot technique, where the sensor sends the IR rays on to the floor and it receives back the rays. If the people is present in the floor, there will be a temperature difference observed on the floor, so that it is noted that there is some activity occurring, that describes the availability of person in the floor which sends signal to the chiller to turn on and if the person left the room, it sense the activity for 10 minutes. Even after 10 minutes if there is no activity happening on the floor that means that the people left the floor so that the chiller should shut down to save the excess energy consumed by the chiller. By this process a huge amount of energy is saved. By saving this energy, we can save a lot of money used for the consumption of electrical energy during demand time.

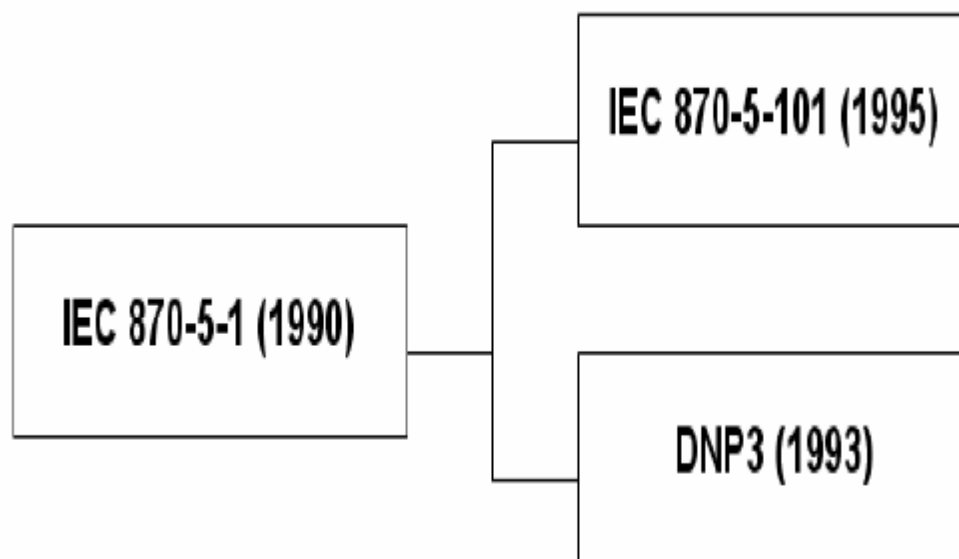

Figure 10: SCADA Protocol Distribution

#### 4.2.1 IETC 603470-5 Protocol

Combined standards are introduced by a group operated by the IEC (International Electro technical Commission). For the control of the system using a SCADA platform this group is introduced and operated globally. It controls the entire SCADA based platform and the equipment to get the source file and to operate globally without disturbances. However IETC 603470-5 protocol is concentrated only in the Europe [3].

During 2005 the IETC 603470-5 publication was transferred from a base model and then during the time course, the usage of the network connectivity and the ability to control remotely was increased that leads to the increased usage of IETC 603470-5 globally. It is similar network protocol used for TCP/IP.

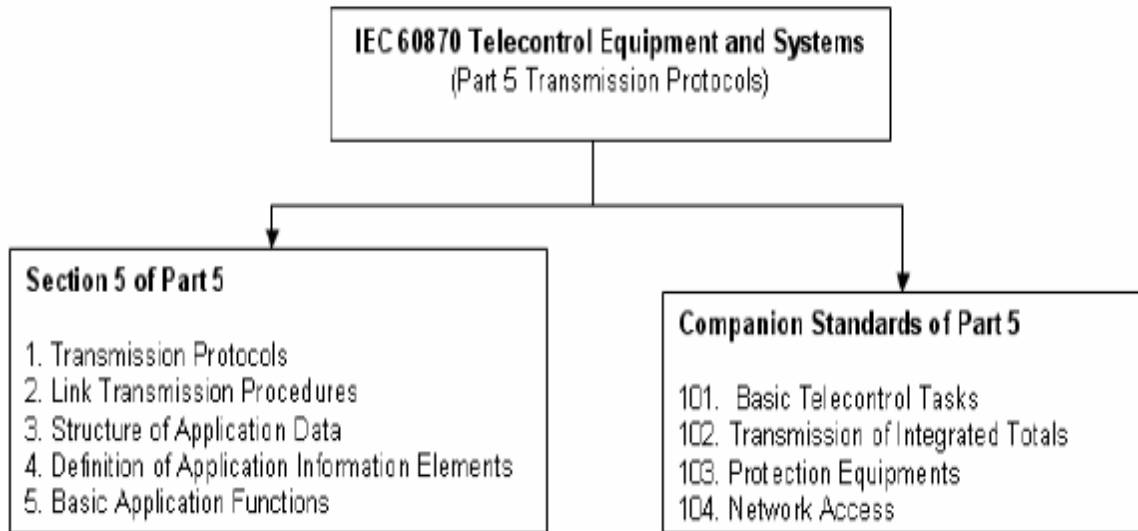

Figure 11: IETC 603470-5 Structure

## 4.2.2 T101 Protocol

IETC 60450-5-101 (IETC101) or T101 is another communication protocol which is used widely and independent with IETC 603470-5. It uses the points list to determine the loads and communicating with the telecommunication channel and has a multiple configuration to change or adapt with the ongoing communication protocols.

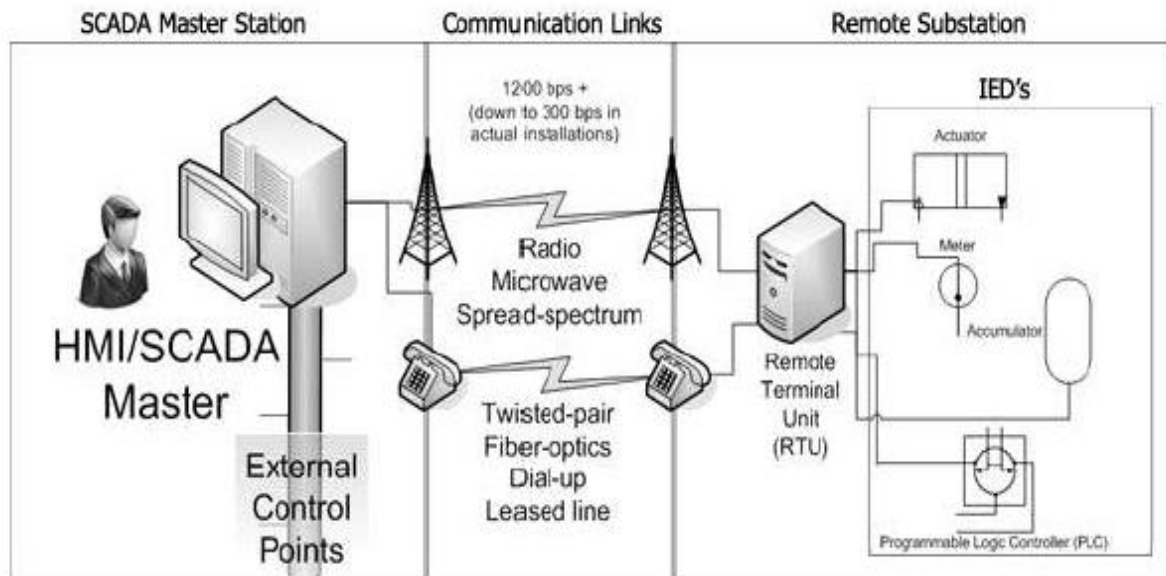

Figure 12: Overview of T101 Protocol

Data communication of T101 and the SCADA system based purely based on the T101 protocol transmission. In many SCADA system, we can see the T101 communication protocol, which helps to increase the system efficiency and the percentage of error is very less when compared with the other commercial protocol available in the market. It is also increase the productivity of the system and the entire efficiency if the system is in stable [6].

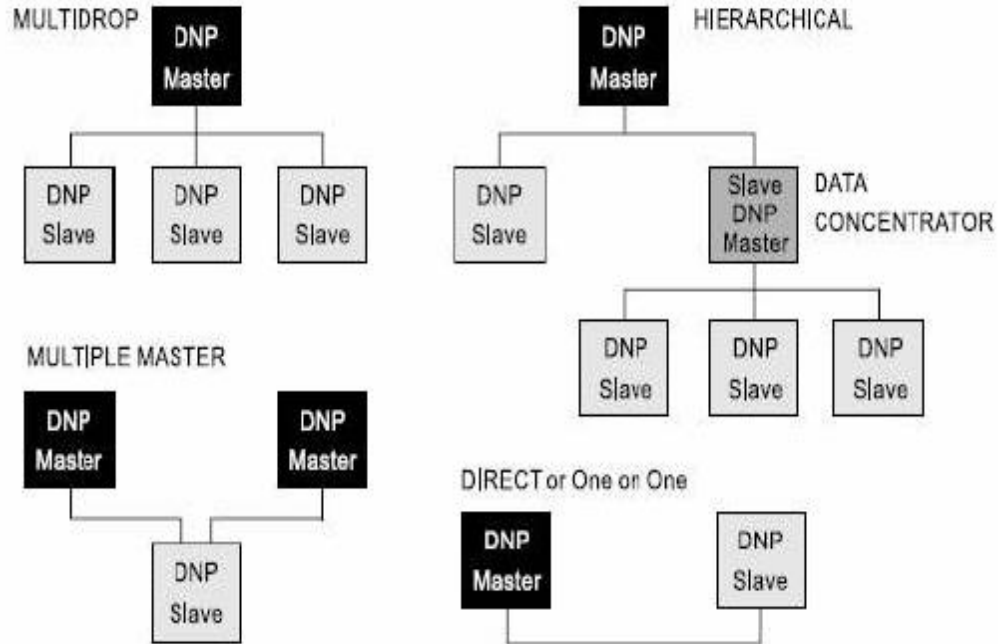

Figure 13: Network Topologies of T101

T101 can be controlled by the client side to avoid the delay and the communication loss occurred during the data transfer and analysis. T101 protocol is used mainly to avoid the disturbances occurs in the data transmission and communication. Many SCADA platform rely mostly on the T101 communication protocol [7].

#### 4.2.3 Conitel

Conitel protocol is another communication protocol which is widely used by the SCADA systems. It is based on the point list information that is collected by the load side. Based on the information, this protocol sends and receives data in order to transmit the information to SCADA system. Conitel has different duplex operation like full and half duplex control. The security of the Conitel is more accurate and precise when compared to the other form of data available in the market. The better way of transmitting data for a SCADA systems are to use the communication protocol that best fits the need of the building management.

## CHAPTER 5: CONTROL OF THE SYSTEM USING SCADA

The data network, TrendLAN, is proprietary to Trend and access via standard protocols is difficult. However, the more modern Trend controllers, IQXNC (see Annexe), once connected to the network, are able to make data available in a standard BACnet IP format. The Gateway server (located also in the plant room, next to the head-end) can function as a BACnet client and is therefore able to communicate with the controller.

In order to make the data available in BACnet format, the IQ3 controllers must be programmed with the data points and the frequency at which the data will be read. It is important to note that each controller can read a maximum of 250 data points, and, given that the Trend network at Atlas House is somewhat dated, the sampling frequency has been set to 5 minutes. This approach has been chosen because Atlas is considered as a pilot for this approach and risk should be minimized.

Because of the limited nature of the pilot, only one IQ3 will be inserted into the network, reading only analog inputs (see list below). In the future, expansion of the pilot will require installation of extra IQ3 controllers.

Engineers will be physically onsite to monitor the performance of the network and act accordingly should any adverse effects be noted. The controllers must also be physically connected to the Trend network. The IQ3 controller will be inserted into the network in the plant room, within a cabinet close to the head-end supervisor and the Gateway Server. This will involve mounting the IQ3 on a DIN rail inside one of the existing panels.

The following diagram illustrates the setup of the existing network. Each node is a controller attached to a particular piece of equipment and is therefore found throughout the site.

### 5.1 Ethernet Logic Controller

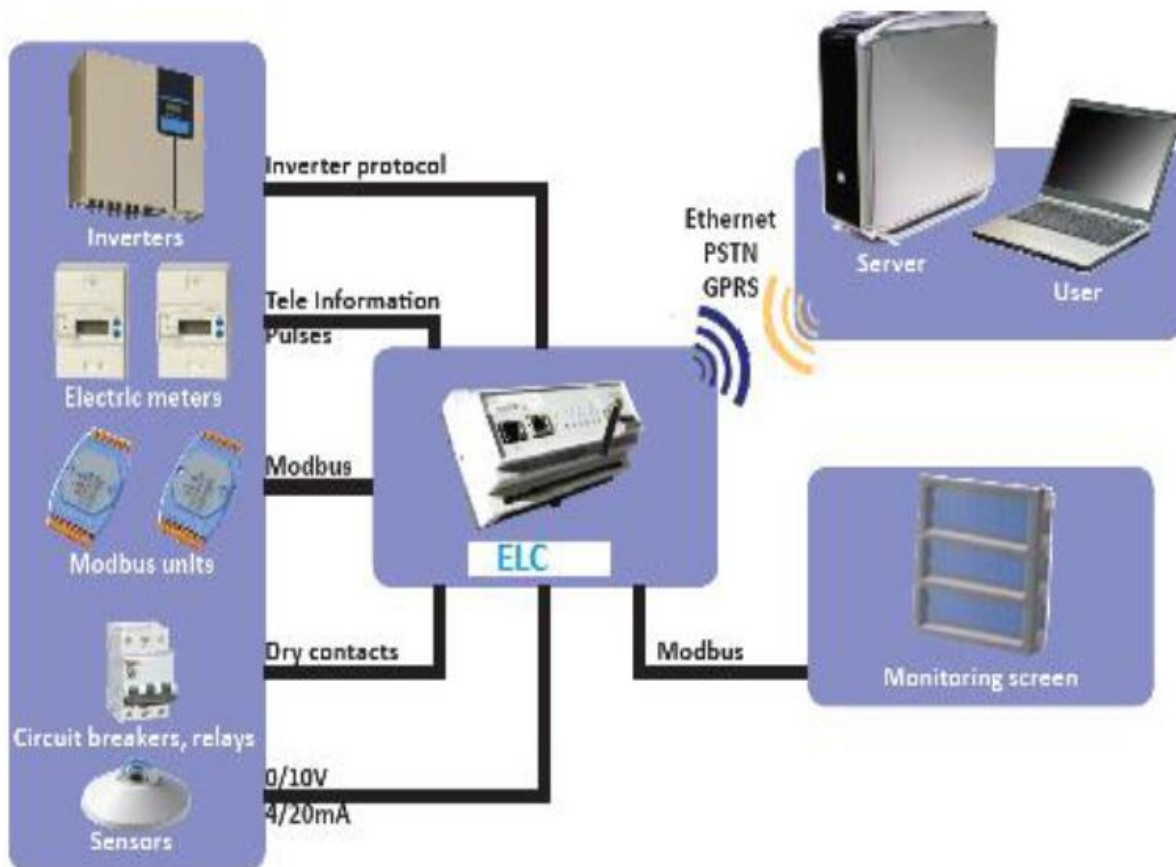

Figure 14: Ethernet Logic Controller

Communication with all available critical sensor and control data streams is ideal, therefore interfacing these individual units with Maestro is recommended. With universal connectivity abilities within our platform, this will allow us to leverage functionality of the installed infrastructure. Unit interface can be achieved by direct communication where available, possibly with third party hardware, or by additional hardware. The goal of the direct communication interface is to first access internal sensor data for analytical purposes and then

access internal control outputs once a valid control strategy has been developed and approved. In the instances where direct communication is not available or unreliable with the unit's on-board controllers, hardware can provide much of the same functionality as the direct interface and will acquire all the telemetry to execute control and optimize behavior of targeted mechanical assets.

The installation plan outlined in this document covers the installation of hardware for total site energy monitoring, load profiling, and building response data. This includes ELCs, SAM meters, and space temperature sensors. The space temperature sensors are located by zones to expand the space temperature data for all valid areas. The approximate locations for these items were chosen based on several perceived factors during site walks. All existing temperature data streams accessible, including unit interfacing and installed zone temperature sensors, and possible airflow distribution problems of existing cooling systems were used to develop the locations of these sensors. After installation preparation has determined the exact locations of these sensors based upon site specific limitations, they will be installed within the vicinity shown on the diagram and calibrated as needed.

During the installation plan detailed in this document, there will be ongoing research and development for interfacing options with all site mechanical assets. As indicated and described earlier this will be performed on a case-by-case basis with the intention to interface with vital mechanical equipment and acquire the complete telemetry needed to propose future control changes and attain optimized operation of every targeted asset. This research and interfacing plan will lead to the development of a detailed report which will address several key items. First, the report will address the detailed interfacing option for each of the facility assets and second, extensive analysis of asset control with its advantages. This report will also include



the complete BOM for the interfacing hardware (MAHU kit, Trend Integrator, Modbus-Serial Card etc.). The previous sub-section outlined the current controls in place for existing equipment. The complete ability of the existing system controls coupled with Maestro supervisory abilities with necessary interfaces in place will provide valuable data about the site that will help determine and propose future control implementation plan. Next, a detailed optimization strategy and complete engineering report will be developed. Upon complete implementation, the site will be fully commissioned with telemetry available for all targeted mechanical assets, localized building responses, and site energy consumption. In order for us to connect and to collate all these data streams from disparate hardware, we will install Maestro Supervisory BMS. Compiling these data streams into a centralized source allows for several key analysis tools that are outlined below.

- (a) Live Data Monitoring of All Component Power Use (Baseline) and Sensor Data (Environmental)
- (b) Computation of Component and Total Grouped Systems Efficiency
- (c) Ability to Model and Simulate for Optimal Operating Conditions
- (d) Set Point Validity
- (e) Control Strategy Optimization

When a sufficient amount of data has been collected (generally 30 days), the information determined about system and control efficiency will be used to develop the optimization schedule and ideal control implementation for this specific site. The development of the control strategy after full telemetry is available will allow for the understanding of site efficiency from factors that are not visible from simply looking at the operation of the site.

The information gathered in the site behavior analysis phase is where the bulk of our solution is derived (Phase 4 in CW Phase Definitions and M&E Requirements PowerPoint). With all the information gathered into a centralized location, we will be able to determine operational inefficiencies of the systems in their currently installed configuration. The system has been commissioned, our control strategy optimization proceeds through analysis of the set-points, building response, and control methods for individual components and for the total system. This analysis is then used to develop improvement for all possible problem areas determined. The Maestro platform will then act as a total system controller. However, all control strategy or system changes will be submitted to facility management for approval before implementation. This allows for system control decisions to be made with optimized total system efficiency with site specific conditions taken into account instead of disparate component controllers optimizing their respective efficiencies with limited data.

## 5.2 Implementing SCADA to a Building BMS

Taking a building into consideration, collecting site information like floor plan, facility area, electrical consumption of the building,

### 5.2.1 General Information of the Site

Hilington Bude site is a 2,009 m<sup>2</sup> (21,627 ft<sup>2</sup>) property has dedicated Office area of 28m<sup>2</sup> (300ft<sup>2</sup>) along with Non office area of 1,981 m<sup>2</sup> (21,327 ft<sup>2</sup>).

Bude is a one story building. It functions as a cable landing station which supports the transatlantic cable system Apollo.

The site contains 7 communication rooms,

- (a) BDEN04
- (b) BDEN05

- (c) BDEN06
- (d) BDEN07, is empty
- (e) BDEN08, is empty
- (f) BDEN09
- (g) BDEN10, is empty

The site is equipped with a BMS system. The PC is no longer operational, but the Trend gateway was functioning on the day of the site walk. A direct connection to the Trend system is required to gather all the pertaining data. Annual electric consumption of 1,879,957 kWh (total annual cost is £191,672).

#### 5.2.2 Systems Description

##### (a) BDEN04

1. Airedale DFCW24 are located in the corridor along BDEN04
2. These AHUs are down drafted with supply air into open floor and return air from BDEN04 wall mounted vents.
3. There are also 2 extract fans located in the plant room next to BDEN04, extracting air from the plant room to BDEN04.

##### (b) Plant room 5&6 (for BDEN05 and BDEN06)

1. 2 Airedale DFCW20 are down drafted with supply air into open floor and return air from BDEN05 wall mounted vents.
2. There are also 2 extract fans located in the plant room, extracting air from the plant room to BDEN06.
3. 2 Airedale DFCW20 are down drafted with supply air into open floor and return air from BDEN06 wall mounted vents.

4. There are also 2 extract fans located in the plant room, extracting air from the plant room to BDEN06.
- (c) Plant room 7&8 (for BDEN07 and BDEN08)
1. 2 Airedale DFCW20 are down drafted with supply air into open floor and return air from BDEN07 wall mounted vents.
  2. There are also 2 extract fans located in the plant room, extracting air from the plant room to BDEN07.
  3. 2 Airedale DFCW20 are down drafted with supply air into open floor and return air from BDEN06 wall mounted vents.
  4. There are also 2 extract fans located in the plant room, extracting air from the plant room to BDEN06.
- (d) BDEN09
1. The AHU are located in the plant room 9 (the room between BDEN09 & BDEN10).
  2. Airedale DF100CW-AT are down drafted with supply air into open floor and return air from BDEN09 wall mounted vents.
  3. There are also 2 extract fans; extracting air from the plant room to BDEN09
- (e) BDEN10 (empty room)
1. There are also 2 AHU which supply fresh air in rooms (BDEN04 & BDEN09) and plant rooms.
  2. Chillers + pumps
  3. 1 Airedale Delta Chill DCF035DR-08-BMM0 Chiller
  4. 2 Airedale Ultima USC750DQ-16 chillers

### 5.2.3 Facility Energy Consumption Statistics Table

Table 2: Facility Energy Consumption Statistics

Site Name	Bude
Total Building Area	2,009 m <sup>2</sup> (21,627 ft <sup>2</sup> )
Office area	28m <sup>2</sup> (300 ft <sup>2</sup> )
Non Office space area	1,981 m <sup>2</sup> (21,327 ft <sup>2</sup> ).
Annual Electric consumption[kWh]	1,879,957
Annual Electric consumption[£]	£191,672
Cost [£/kWh]	0.101 £/kWh
Ratio [kWh/(m <sup>2</sup> .year)]	935.76

Table 3: Energy Consumption Table

Month	Consumption		
	(kWh)	GBP(£)	USD(\$)
Jan -12	172,204	£16,738	25,562
Feb -12	162,988	£15,822	24,163
Mar -12	177,171	£17,155	26,199
Apr -12	170,476	£16,564	25,296
May -12	153,863	£15,251	23,291
June -12	143,394	£14,285	21,816
July -12	156,618	£15,531	23,718
Aug -12	154,812	£15,344	23,433
Sep -12	141,980	£14,159	21,623
Oct -12	148,966	£17,000	25,962
Nov -12	147,387	£16,733	25,554
Dec -12	150,098	£17090	26,099
<b>Total Annual Consumption</b>	<b>1,879,957</b>	<b>£191,672</b>	<b>292,721</b>

### 5.2.4 Floor Plan

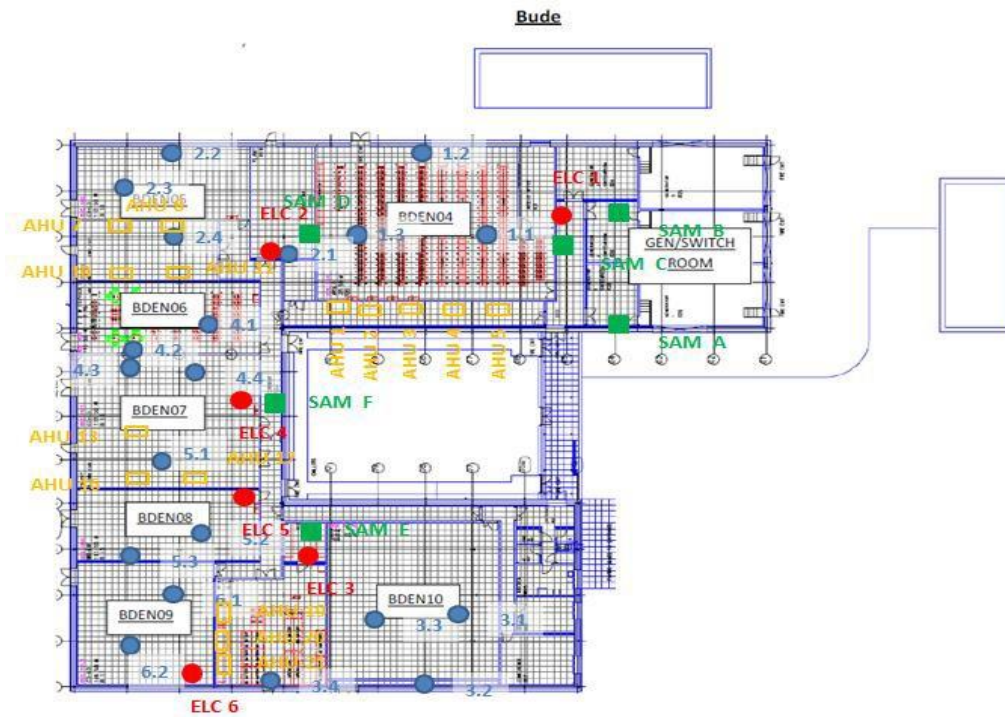

Figure 15: System Architecture for Energy Consumption

### 5.3 Coding Flowchart

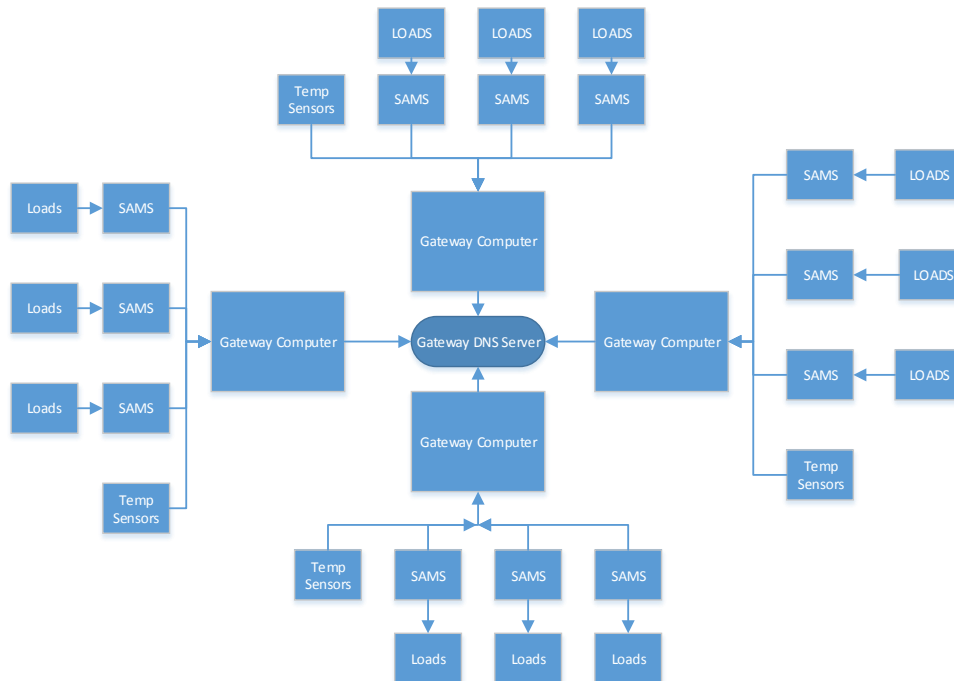

Figure 16: Coding Flow Chart for a Proposed System

## CHAPTER 6: CONCLUSION

Based on my studies, it describes how a building is implemented with smart building techniques so that the power and Energy consumption can be minimized using advanced SCADA techniques. The chillers and the other building loads can be controlled and operated periodically with respect to time and requirement so that the energy and cost savings can be done wisely.

Human sensing methods and implementing on the plant also with the temperature sensors placed accordingly to monitor and control using SCADA software and operated from a distance place, which reduces the man power and increases the efficiency of the plant to the maximum and getting back the returns in the short time.

This covers how the building is taken into remote access and using SCADA as a communication platform, the loads and equipment are controlled remotely and maintained at the optimum level. By keeping the system in optimum level, the cost for the consumption of electrical loads is decreased drastically. Thus gives the complete control of the building with highly efficient controllers. In future, the research work will be implementing the SCADA platform to a chiller plant where the data's are sampled, monitored and controlled with more efficient FDD methods. Thus reducing the operating cost of the chiller and the performance of the chiller is increased remotely with very low consumption charge.

## REFERENCES

- [1] “What is a Smart Building?” Siemens Industry, 2010.
- [2] “Smart Building”, <http://www.smart-buildings.com/faqs.html> 2010.
- [3] “What is Smart Building?” TriplePundit , <http://www.triplepundit.com/2013/02/smart-building/> , 2013.
- [4] Dr. Abdulmohsen Al-Hammad , “BUILDING MANAGEMENT SYSTEM (BMS) “.
- [5] SCADA, “<http://en.wikipedia.org/wiki/SCADA>”.
- [6] “Energy Efficiency Trends in Residential and Commercial Buildings” October 2008.
- [7] “How to save electricity” <http://www.wikihow.com/Save-Electricity>.
- [8] “Saving Electricity”, <http://michaelbluejay.com/electricity/>.
- [9] “Maestro software” [http://en.wikipedia.org/wiki/Maestro\\_\(software\)](http://en.wikipedia.org/wiki/Maestro_(software)).
- [10] “Microchip”[http://www.microchip.com/stellent/idcplg?IdcService=SS\\_GET\\_PAGE&no deId=1406&dDocName=en020194](http://www.microchip.com/stellent/idcplg?IdcService=SS_GET_PAGE&no deId=1406&dDocName=en020194).
- [11] Quantum Consulting Inc. and Summit Blue Consulting, LLC. 2004. Working Group 2 Demand Response Program Evaluation – Program Year 2004 Final Report. Prepared for Working Group 2 Measurement and Evaluation Committee. Berkeley CA and Boulder CO, December 2001.
- [12] Eto, J., J. Nelson-Hoffman, C. Torres, S. Hirth, B. Yinger, J. Kueck, B. Kirby, C. Bernier, R. Wright, D. Watson. Demand Response Spinning Reserve Demonstration. LBNL62761. May 2006.



- [13] Peter Palensky, Senior Member, IEEE, and Dietmar Dietrich, Senior Member, IEEE, “Demand Side Manage.
- [14] “Supervisory control and data acquisition (SCADA) System”, October 2004.
- [15] Debnath Bhattacharyya, “The Taxonomy of Advanced SCADA Communication Protocols” 2008.
- [16] C. Clarke, D. Reynders and E. Wright, Practical Modern SCADA Protocols: DNP3, 60870.5 and Related Systems, 2004.
- [17] SCADA - Wikipedia <http://en.wikipedia.org/wiki/SCADA> Accessed: December 2008.
- [18] DNP3 - Wikipedia <http://en.wikipedia.org/wiki/DNP3>, Accessed: December 2008.
- [19] DNP Users Group, Overview of the DNP3 Protocol, <http://www.dnp.org/About/Default.aspx> Accessed, December 2008.
- [20] DPS Telecom –DNP3  
“Protocol[http://www.dpstele.com/dpsnews/techinfo/dnp3\\_knowledge\\_base/dnp3\\_protocol.php](http://www.dpstele.com/dpsnews/techinfo/dnp3_knowledge_base/dnp3_protocol.php)”, Accessed: December 2008.
- [21] Wikipedia - Modbus <http://en.wikipedia.org/wiki/Modbus>, Accessed: December 2008.
- [22] SCADA SYSTEM, [www.motorola.com/governmentandenterprise](http://www.motorola.com/governmentandenterprise) 2007.

## APPENDICES

## Appendix A General Information About Appendices

A site has been taken into account for implementing the procedure and concludes the result of the project.

The main aim of our given technique is to use power in efficient manner. Controlling all the devices at system level is not useful for efficient power consumption. Thus for efficient power consumption we have to control all the devices at equipment level. Our proposed equipment architecture is mainly divided into three main parts. In first step we collected the data from various devices like SAM meter, temperature sensors such that to reduce the energy consumption of each device. These reading will send to equipment level like ELC. ELC reads the data from the current transformer and process it before we can read the data from the ELC. This equipment sends the data to gateway server for monitoring server. The gateway sever monitor data received from previous equipment and sent it to control strategy development part for analyzing purpose. The information collected is dumped and analyzed to get the optimum and most efficient result. This collected data is then simplified and analyzed to get a better understanding of the electrical controls of the building and to build an optimum threshold factor like temperature, demand power and the peak voltage of the equipment. The control strategy development analyzes the data and made some decision. In last step we implemented the analyzed data and it gives the appropriate output. In our thesis, we are using SCADA software for controlling purpose, Mata lab 2010, VMC 5.0, Band Automation Studio 3.0.81 and VM VARE work station 8.0. Here we are describing the controlling mechanism in the form of snapshots given below.

## Appendix A (Continued)

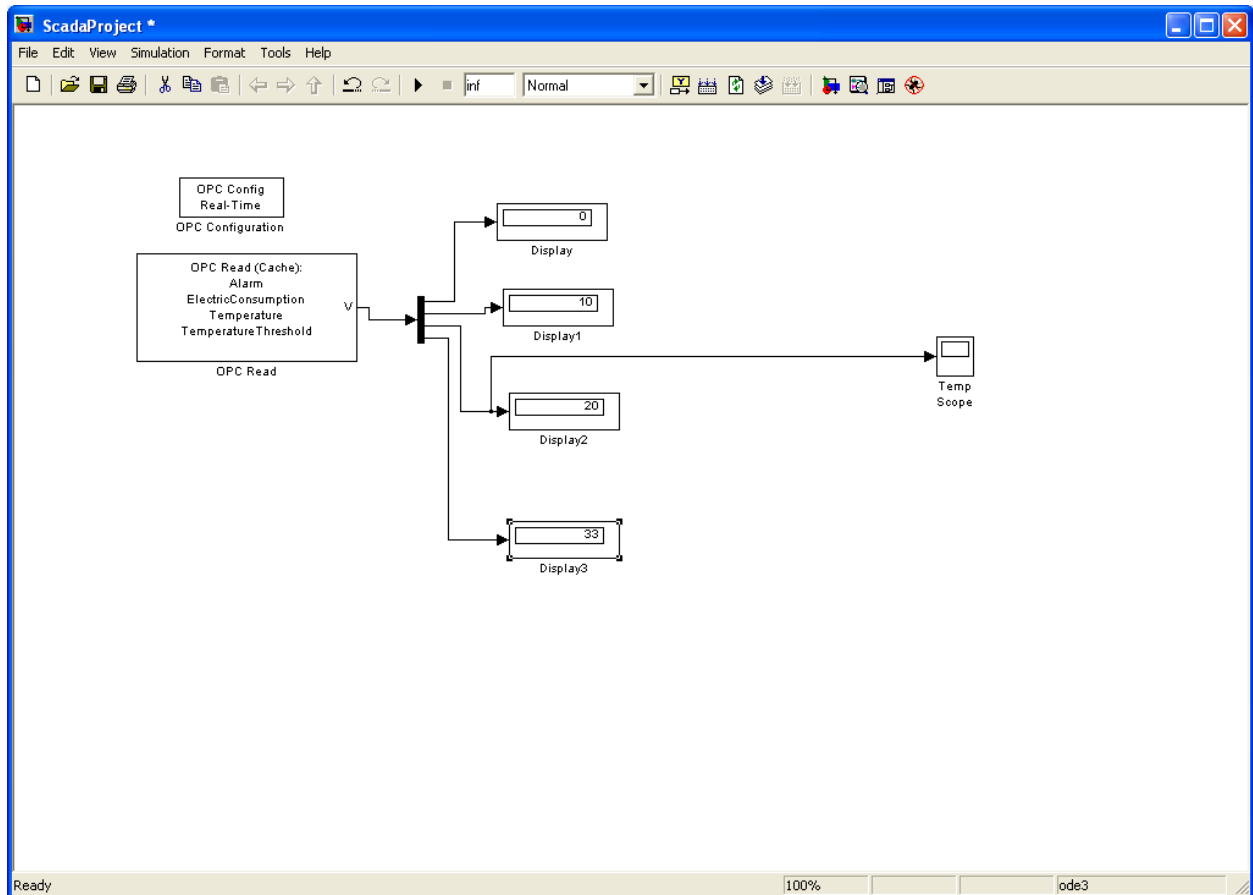

Figure A.1: Controller Diagram of SCADA PLC

It's a main GUI for the SCADA PLC which shows the complete SCADA Simulink created in Matlab. From here we can read the data through some data reading meter. Alarm is used for rising temperature above threshold. Whatever reading will change in VNC, it will reflect here.

After the SCADA project is simulated in Matlab OPC Toolbox the server responses to the Matlab and all the details are updated in all the screens. It also shows the Progress, in the status bar below.

## Appendix A (Continued)

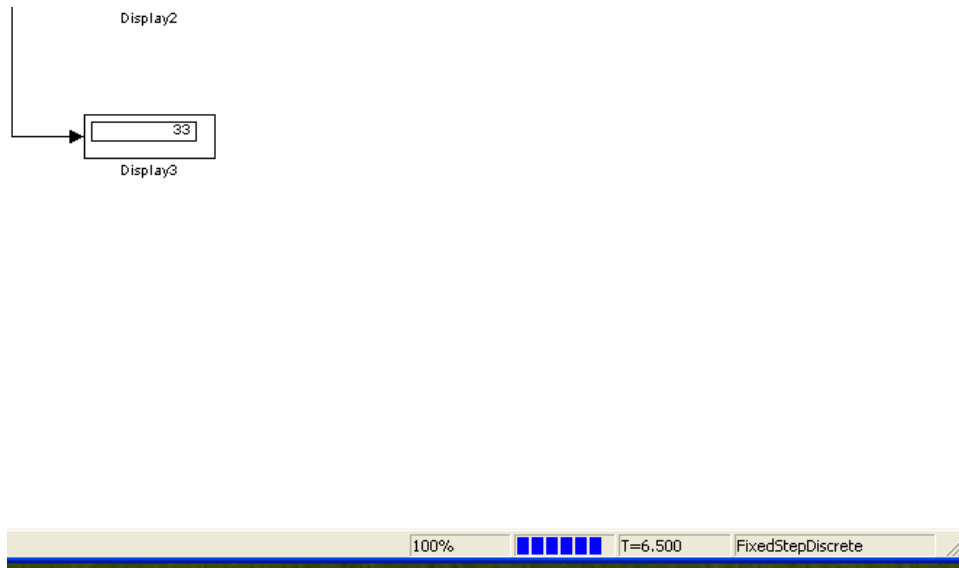

Figure A.2: A Runtime SCADA Controller

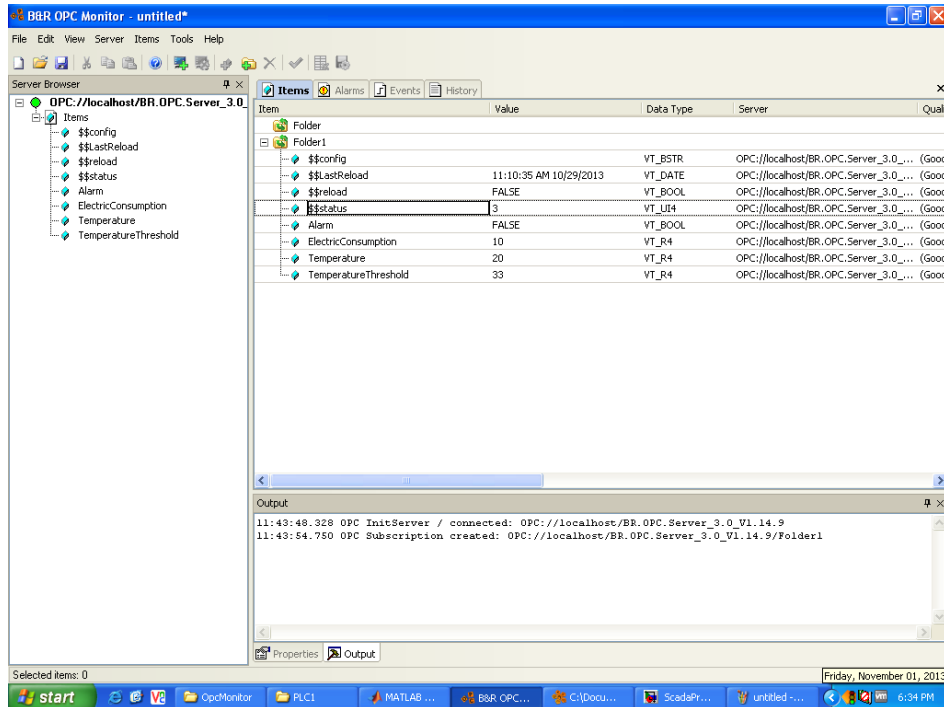

Figure A.3: B&R OPC Monitor Tool

It is used for monitoring the real time operation on SCADA.

Appendix A (Continued)

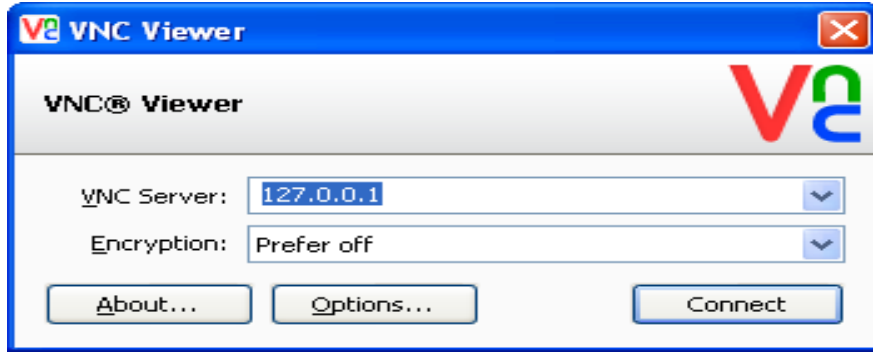

Figure A.4: Using VNC for Remote Access and Control

Similar to the Control Maestro software, VNC is a remote access tool. It uses the point to point basis with a simple coding and architectural protocol. By using the SCADA server, we can manage the values populated in this system.

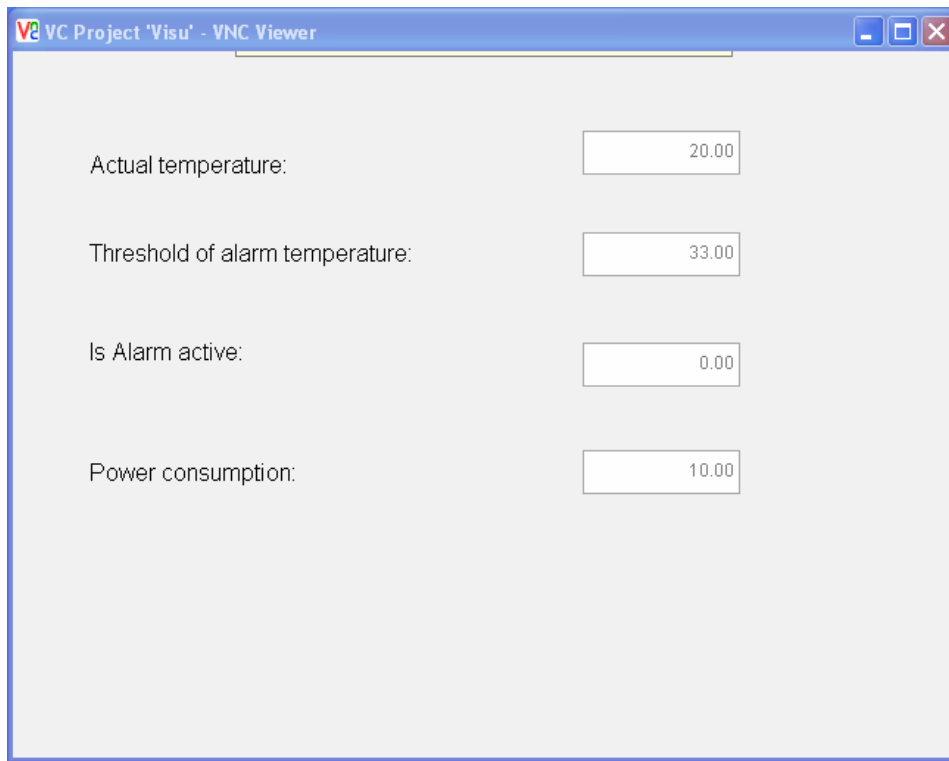

Figure A.5: VNC SCADA Panel

The above figure A.5 shows the parameter of the SCADA server for the VNC.

## Appendix A (Continued)

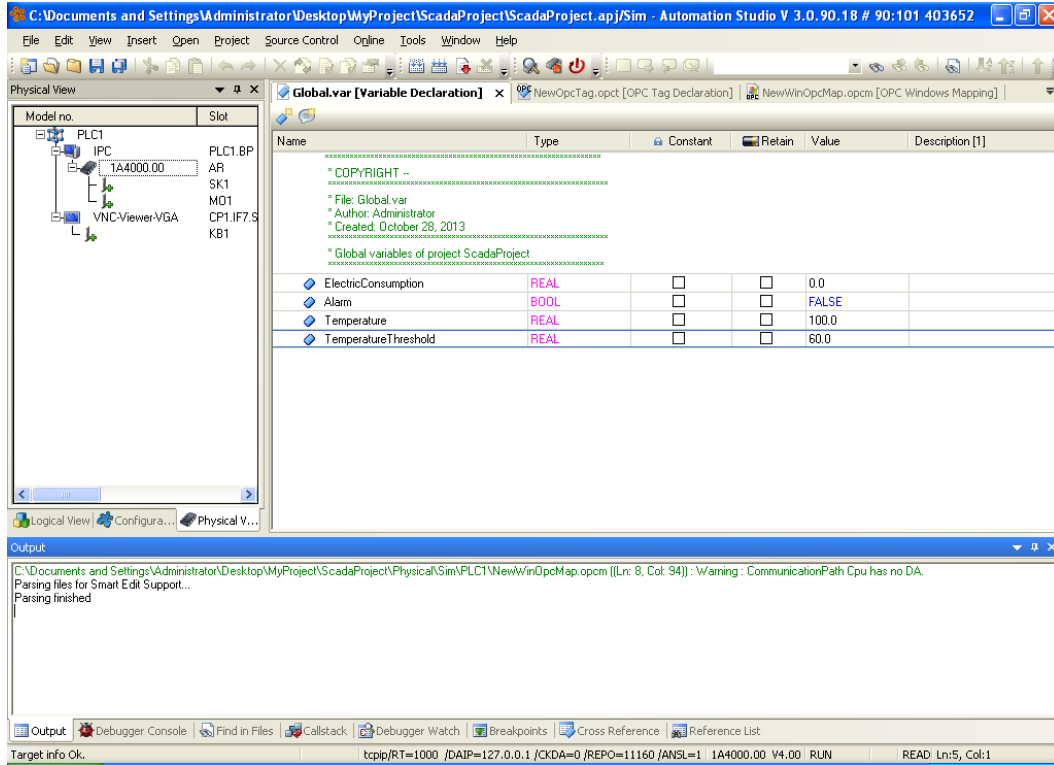

Figure A.6: SCADA Server Simulator

It is the part where we monitor and administer the components of the SCADA server and scope for the VNC control, so that we can manage it form VNC.

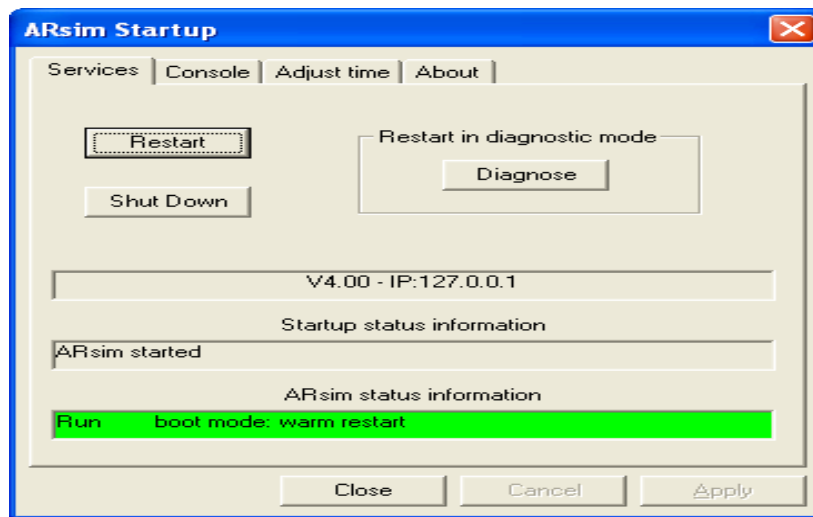

Figure A.7: SCADA Simulator Manager

## Appendix A (Continued)

It is the main AR simulator which server the complete SCADA without hardware. This component is found the system tray , we can manage it for starting and stopping the services.

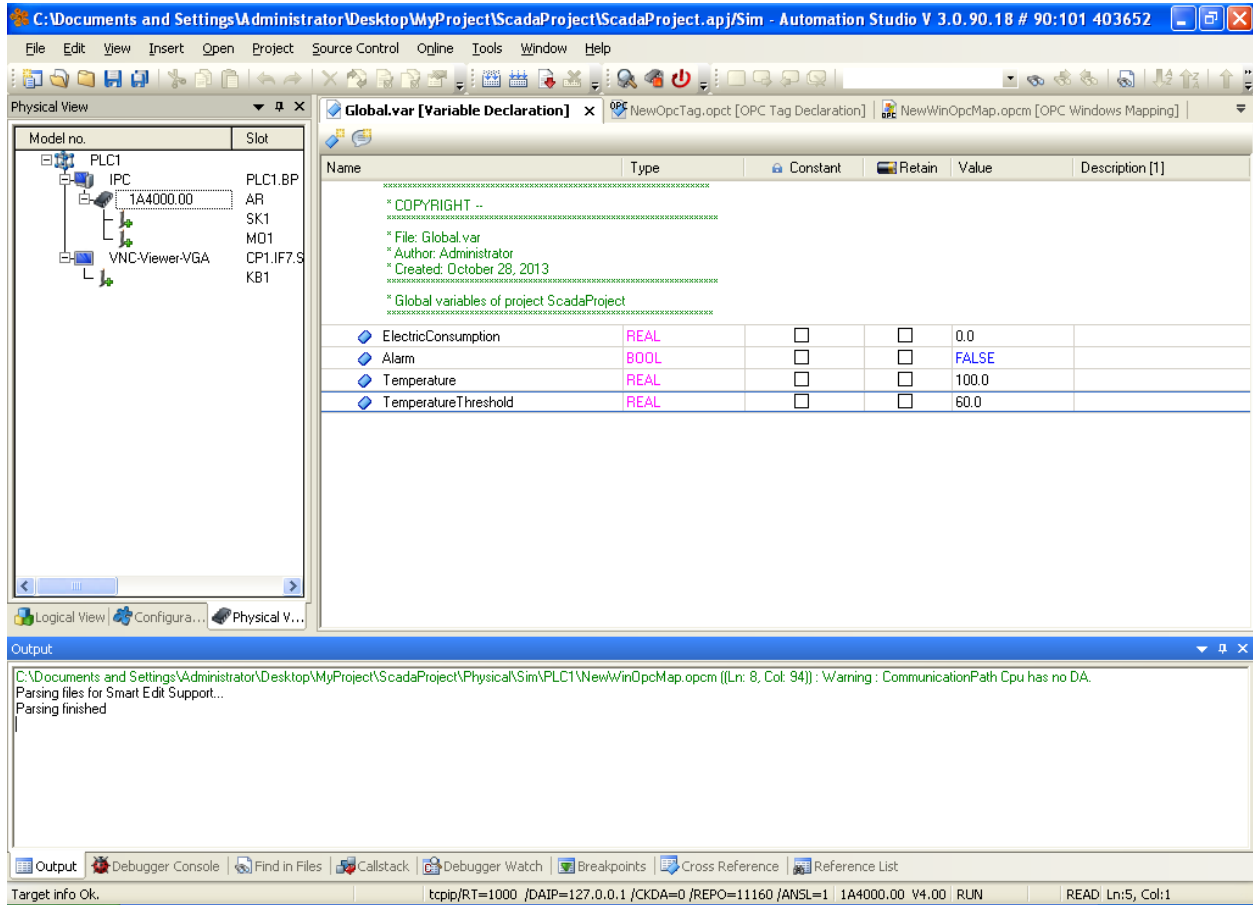

Figure A.8: SCADA Server Simulation

It is the configuration panel where we have specified the complete SCADA server and their components.